

# Electronic Design and Solution Fair 2007

with FPGA/PLD Design Conference

## Guide for Emerging Company Area

World-Leading Technologies – Yours to Discover

[www.edsfair.com](http://www.edsfair.com)



# Agenda of EDSFair Breakfast Meeting at DAC

**Outline of EDSFair 2007**

**Features of “Emerging Company Area”**

**Details of “Emerging Company Area”**

# Electronic Design and Solution Fair 2007

with FPGA/PLD Design Conference

## Outline of EDSFair 2007

Electronic Design and Solution Fair 2007

Executive Committee

**General-Chair Mitsuru Nadaoka**

World-Leading Technologies – Yours to Discover

[www.edsfair.com](http://www.edsfair.com)



# What is EDSFair?



***DATE***



***EDSFair***



***DAC***



**JEITA**

**EDA**  
CONSORTIUM

**EDSFair is one of three major EDA exhibitions held in Japan.**

**(EDAC is supporting EDSFair to attract overseas Emerging companies)**

# Comparison of DAC and EDSFair

## Exhibition period and visitor numbers

Name of the exhibition	Date	Location	Number of visitor
DAC (Design Automation Conference 2005)	June 13 - 17, 2005	California, U.S.A	14,700
EDSFair 2006 (Electronic Design and Solution Fair 2006)	January 26-27, 2006	Yokohama, Japan	11,003

## Number of Exhibitors

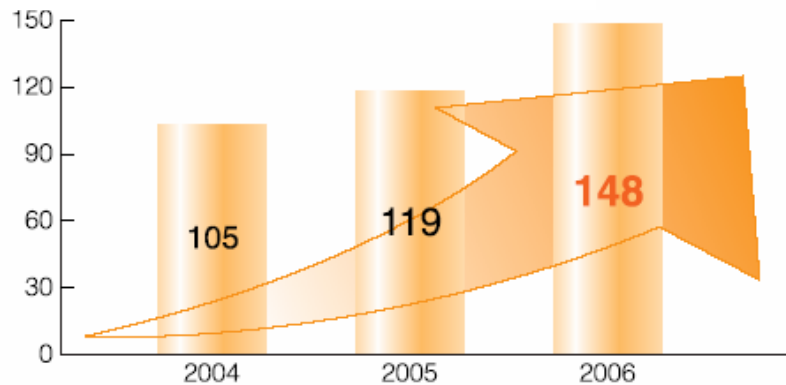

## Number of Booths

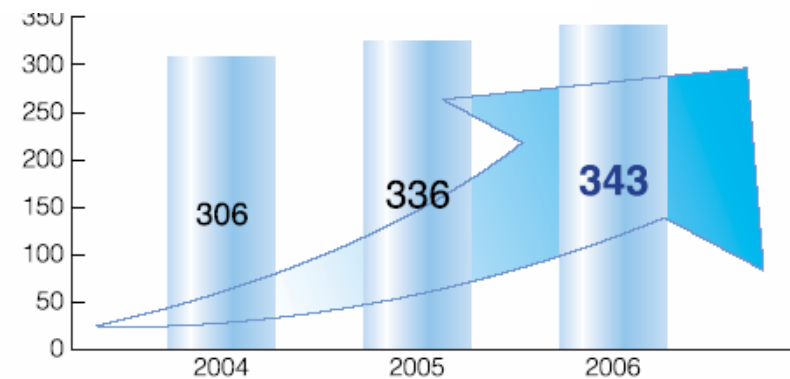

# Outline of EDSFair 2007

## **Schedule :**

**January 25-26, 2007 10:00 to 18:00**

## **Location :**

**Pacifico Yokohama, JAPAN**

## **Constituent part :**

**Exhibition, Exhibitor's seminar,  
FPGA/PLD Design Conference,  
SystemC / SystemVerilog User Forum**

## **Simultaneous event**

**Asia and South Pacific Design Automation Conference (ASP-DAC) 2007**

## **Sponsor :**

**Japan Electronics and Information Technology Industries Association (JEITA)**

## **Cooperation :**

**Electronic Design Automation Consortium (EDAC)**

## **Support :**

**Ministry of Economy, Trade and Industry of Japan (METI)  
Embassy of United States of America in Japan**



**View of Pacifico Yokohama**

# Outline of EDSFair 2007 (2)

## **Exhibition Category :**

- IC design tools**
- Design methodologies**
- Design for manufacturing solutions**
- IPs**
- Embedded software in SoCs**
- Various design services**

**and many other topics that affect today's electronic circuits and systems design**

# Visitor Profile

## Business Category

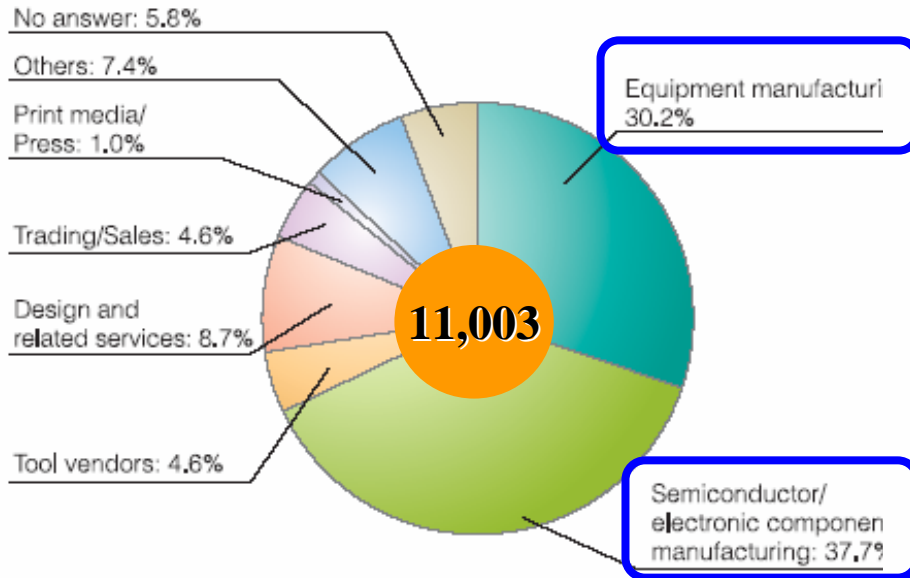

## Occupation Category

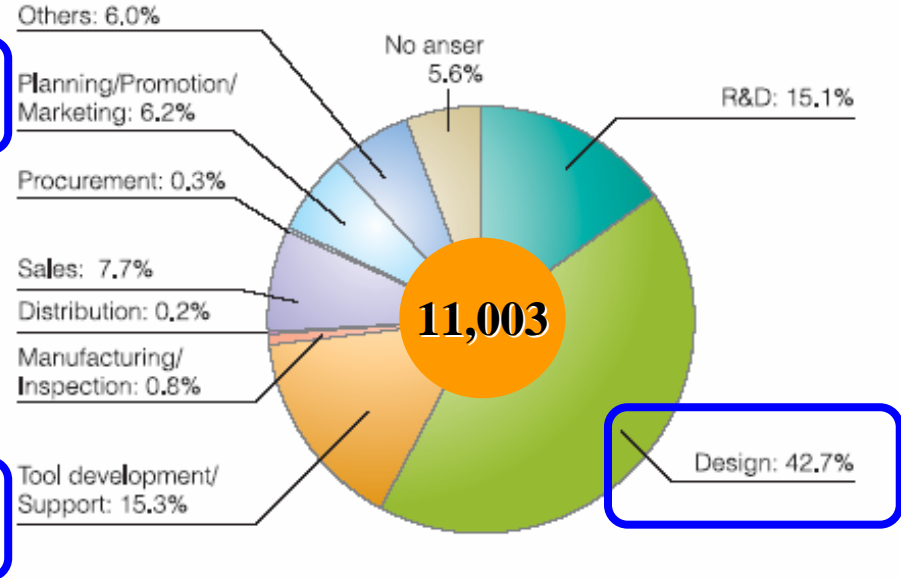

**Visitors are not only Semiconductor companies but System companies**

**Visitors are not only EDA engineers but Designers.**



# Objectives of EDSFair

1

To promote and disseminate the state-of-art information of design solutions, design technologies, and EDA technologies required for the latest electronic systems or semiconductors.

2

To contribute for development of the electric device industry through above activities.

**To achieve these objectives, we will  
Provide Opportunities for Communications  
between Exhibitors and Visitors as much as possible**

# Features of EDSFair 2007

## **Promo Word**

World-Leading Technologies - Yours to Discover

## **Main Projects to achieve objectives are as follows**

- Attraction of "Emerging companies"  
by **Emerging Company Area**
- Tutorials for the beginners and on Technology trend  
at **Special Presentation Stage**

These are planned by visitor survey analysis result

To get more visitors

We will do **Aggressive Promotion by Media  
Before and After Exhibition**

# Project for Emerging companies

## **“Emerging Company Area”**

This is special section for Emerging companies, "Low cost" and "High added value".

This Area is just for the exhibitors, **which have not exhibited no more than twice in the past EDSFair Exhibitions.**

(Details will be explained later)

## Project for Emerging companies (2)

**As Emerging Company Event  
on the Previous day of EDSFair, January 24.**

**We are planning “Seminar on How to establish  
Sales channel in Japan” for Emerging Companies.**

**Questionnaire for Emerging Company**

To be sent in next month via EDAC.

(Example) What are your requests for EDSFair ?

# Special Presentation Stage

**Location is in the Exhibition Hall**

**Program will be:**



**Technology Trend Presentations & Panel Discussions on**

- Foresights of Semiconductor Industry and its Technology**
- ESL**
- DFM & Nanometer Design Challenge**
- Analog / RF**
- SiP Design Technology**

**Emerging Company Area Exhibitor Presentation**

(This will be Heavily announced as one of the key event for EDSFair 2007)

# Aggressive Promotion by Media before Exhibition

## To get more visitors

**We will ask following Japanese key media  
to cover EDSFair**

Nikkei Electronics EDA Online, EETimes Japan,  
EDN Japan, EDA Express, etc.

**We will submit “Special column” to these media on  
Exhibit highlight, Hot topics, What’s new,  
How to walk EDSF, etc.**

**These EDSFair topics will be delivered via E-blast by  
key media and EDSFair.**

# EDSFair Review Article after Exhibition

To ensure sustainable effect of your exhibit,  
Review article of Emerging Company Area will be carried



EDS Fair2006 ベンチャー・カンパニー・バビリオン出展企業一覽と記事へのリンク		
DFM	米Aprio Technologies Inc.	記事
	独MunEDA GmbH	記事
	米Pyxis Technologies Inc.	記事
RF	シンガポールAdvanced RFIC (S) Pte Ltd.	記事
	ギリシャHelic S.A.	記事
低電力化	米Azuro Inc.	記事
論理検証	米Axiom Design Automation社	記事
	米SynapticCAD Inc.	記事
	米Verific Design Automation, Inc.	記事
C言語入力/合成	米Impulse Accelerated Technologies, Inc.	記事
システム性能評価	米Mirabilis Design Inc.	記事

# Electronic Design and Solution Fair 2007

with FPGA/PLD Design Conference

Features of “Emerging Company Area”

Electronic Design and Solution Fair 2007

Executive Committee

**Visitor-Working Group Chair**

**Koji Mugita**

World-Leading Technologies – Yours to Discover

[www.edsfair.com](http://www.edsfair.com)





## Emerging Company Area

**Provide access for business opportunities to overseas Emerging companies having neither operation nor representation in Japan.**

**We will work hard to ensure the success of the Emerging Company Area, which represents as the major highlight in the EDSFair 2007**

# Features of “Emerging Company Area”

**1**

**Low cost**

**2**

**High added value**

**3**

**Highly Visible in EDSFair 2007 planning**

**4**

**High Return on Investment**

**5**

**Low operating cost**

# Features of “Emerging Company Area”

**1**

## **Low cost**

### **Regular Exhibition at**

**¥384,300**

¥294,000 for the smallest booth space (2.97 m x 2.97 m)

¥90,300 for rental booth and other equipment

### **Emerging Company Area Exhibition at**

**only ¥210,000**

covers both minimum booth space (2.0 m x 2.0 m) and rental costs.

# Features of “Emerging Company Area”

**2**

**High added value**

**Special Presentation Stage**

**Easy Access to Communication Area**

**Aggressive promotion  
to get media exposure**



**Additional promotion service can be offered  
with low cost**

# Features of “Emerging Company Area”

**3**

**Highly Visible in EDSFair 2007 planning**

**We will set up an area that is easily accessible for visitors**

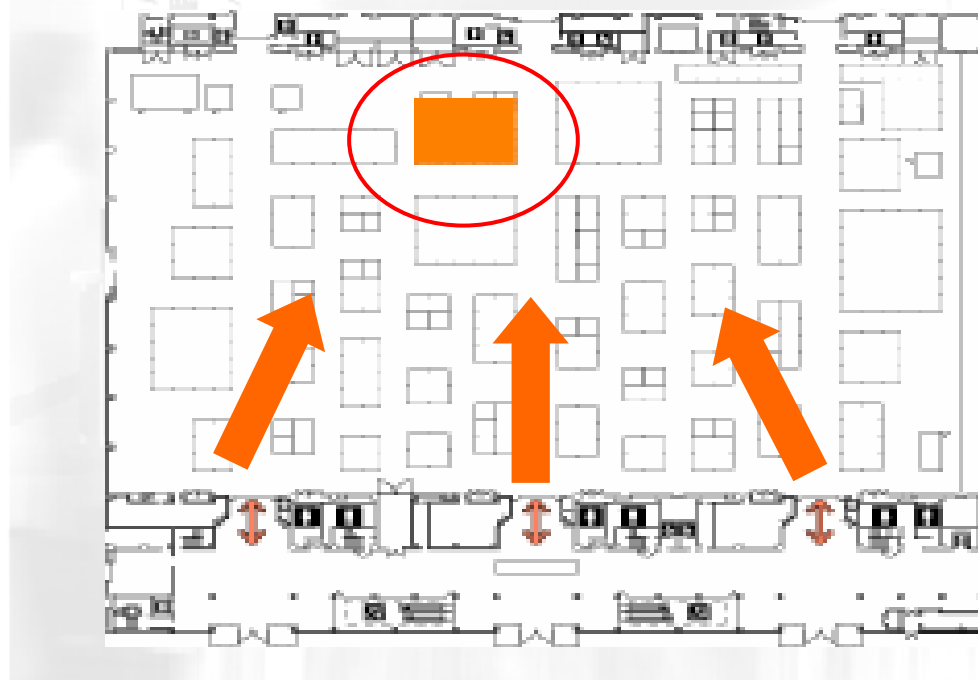

# Features of “Emerging Company Area”

**4**

## **High Return on Investment**

**The area is a highly visible part of this year’s  
EDS Fair planning**



**You can look forward  
a highly cost-effective result**

# Features of “Emerging Company Area”

**5**

## **Low operating cost**

**Aforementioned services are designed to maximize productivity during EDS Fair 2007**

**+**

**Assisting information for your preparation on our web  
Further assists available from EDS Fair Management  
Office**

**||**

**Exhibitors in the Emerging Company Area will be able to gain maximum benefits with minimum effort.**

## Details of “Emerging Company Area”

### **Target participants**

**Overseas vendors, which have not exhibited no more than twice in the past EDSFair Exhibitions.**

### **Booth configuration**

**1 booth:**

**2,000 mm(W) × 2,000 mm(D) × 2,700mm(H)**

### **Exhibition fee**

**JPY210,000 (including tax)**



# Details of “Emerging Company Area”

## Items included in the booth fee

- Display space (Demonstration space)
- Emerging Company Area

### Special booth unit

- \* Display stand (with drawers)
- \* Reception counter
- \* Chairs
- \* Lightings
- \* Electric outlet (1-kw worth)
- Special Presentation Stage
- PR assistance service
- Easy Access to Communication Area (Open lounge)

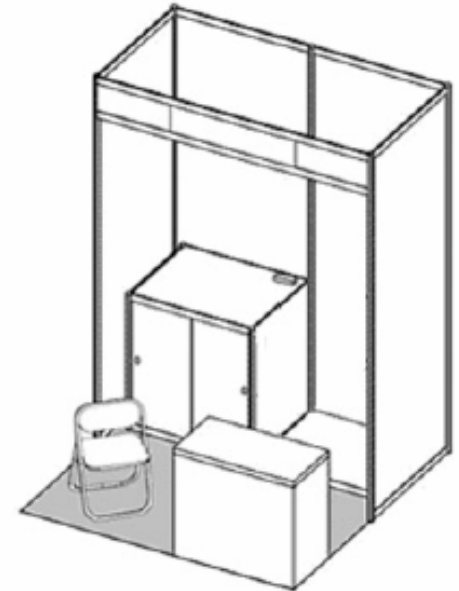

# Application

**Fill in the appropriate application form and  
Submit to JESA by mail (post).**

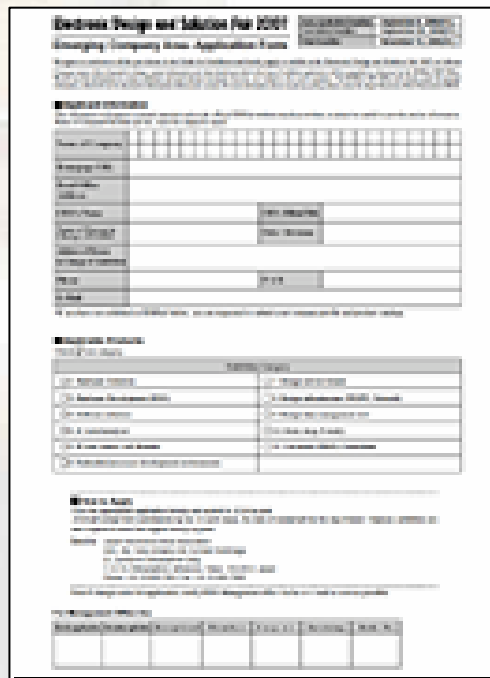

The image shows a screenshot of the application form for the Electronic Design and Solution Fair 2007. The form is titled "Electronic Design and Solution Fair 2007" and "Emerging Company Show Application Form". It contains various sections for company information, contact details, and exhibition preferences. A red arrow points from the form towards the submission address.

**Electronic Design and Solution Fair 2007  
Management Office**

**c/o Japan Electronics Show Association  
(JESA)**

# Quote

**Exhibiting the first time in Japan for our company it was very valuable to do this at the EDSFair Venture Pavilion. We here have found an excellent infrastructure to present our company and products to Japanese companies and interested customers. We met excellent contacts, visiting our booth, to be presented our solutions. I always would recommend to EDA companies new to the Japanese market to exhibit at the Venture Pavilion first and therefore have lot's of success and benefits.**

**MunEDA**

**EDSFair was well organized, well attended and definitely worth the investment. This is gained momentum and now is second only to DAC in USA.**

**Pyxis Technology**

**The EDSFair proved to be very helpful to meet prospective Japanese customers, specifically from semiconductor companies, with a need for our Verilog, SystemVerilog, and VHDL parser technologies.**

**Verific Design Automation**

For further information, please contact:

**Electronic Design and Solution Fair 2007**

**Management Office**

**c/o Japan Electronics Show Association (JESA)**

**URL: <http://www.edsfair.com>**

**TEL: +81-3-5402-7601      FAX: +81-3-5402-7605**

**E-mail: [edsfair.info@jesa.or.jp](mailto:edsfair.info@jesa.or.jp)**

# **Electronic Design and Solution Fair 2007**

**Exhibit at Emerging Company Area  
of EDSFair 2007**

**For the Highest Return on Your Exhibition  
Investment**

**Thank You**

**We Look Forward to See You in 2007 at Yokohama!**

# Electronic Design and Solution Fair 2007

with FPGA/PLD Design Conference

## Guide for Emerging Company Area

World-Leading Technologies – Yours to Discover

[www.edsfair.com](http://www.edsfair.com)

